

GB Instruction for use



POWERTEX Trolley model PGT/PPT-S1



UMPGT/PPT20180913GB

POWERTEX Trolley PGT-S1 and PPT-S1 0,5 – 10 ton Mounting / Instruction for use (GB) (Original instructions)

Read through these user instructions carefully before using the trolley. Improper operation may lead to hazardous situations!

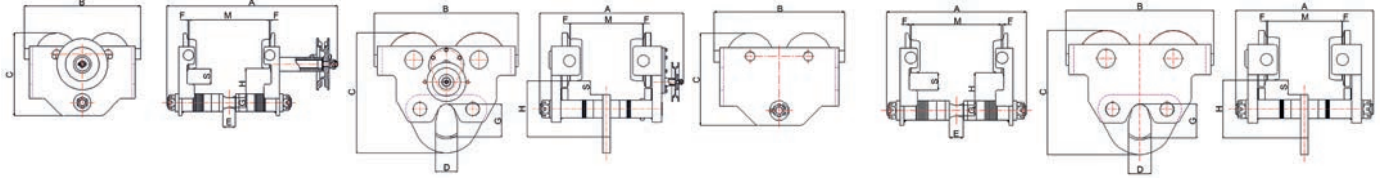

Geared trolley 0,5 - 5t

Geared trolley 10t

Push trolley 0,5 - 5t

Push trolley 10t

Technical data

Model	0,5t PGT	1t PGT	2t PGT	3t PGT	5t PGT	10t PGT	0,5t PPT	1t PPT	2t PPT	3t PPT	5t PPT	10t PPT		
Capacity load t	0,5	1	2	3	5	10	0,5	1	2	3	5	10		
Test load kg	750	1.500	3.000	4.500	7.500	15.000	750	1.500	3.000	4.500	7.500	15.000		
Min. radius of curve m	0,8	1	1,1	1,3	1,4	2,0	0,8	1	1,1	1,3	1,4	2,0		
Dimensions mm	A	a	382	398	420	456	474	402	267	289	318	345	364	380
		b	508	516	526	556	566	504	393	107	424	445	457	482
	B	224	270	300	356	405	485	224	270	300	356	405	490	
	C	159	190	218	262,5	292	395	159	190	218	262,5	292	395	
	D	-	-	-	-	-	72	-	-	-	-	-	72	
	H	57.5 (55.5)	67 (65)	74 (72)	87 (85)	95.5 (93.5)	189	57.5 (55.5)	67 (65)	74 (72)	87 (85)	95.5 (93.5)	189	
	S	30	35,5	36	38	41	45	30	35,5	36	38	41	45	
	E	27	29	43 (35.6)	46	56	-	27	29	43 (35.6)	46	56	-	
	G	18 (22)	22 (26)	28 (32)	34 (38)	39 (43)	112	18 (22)	22 (26)	28 (32)	34 (38)	39 (43)	112	
	F	-	-	1.5-3	-	-	2-3.5	-	-	1.5-3	-	-	2-3.5	
I beam width range	M	a	50-180	66-188	88-200	100-205	114-212	124-203	50-180	66-188	88-200	100-205	114-212	124-203
		b	176-305	184-305	194-305	200-305	208-305	124-305	176-305	184-305	194-305	200-305	208-305	124-305
Net weight kg	a	9	15	22	34	49	87	6	15	18	30	44	86	
		b	9,5	16	23,5	38	56	94	6,5	17	20	34	50	90
Gross weight kg	a	9,5	15,55	22,8	35	50,1	95	6,25	15,3	18,3	30,45	44,65	67	
		b	10	16,55	24,3	39	57,1	102	6,75	17,3	20,3	34,45	50,65	98

Safety factor: 4:1

Static test coefficient: WLL x 1,5

Generally according to EN 13157

1. Proper usage

Usage:

The trolleys can be used for I-beams with plane flanges (such as IPE, HEA or HEB types) or beams with sloping flanges (such as INP-beams).

The possible width ranges are shown in the data tables.

The trolley is a rolling and geared chassis for attaching to lifting gear for use inside.

It is not suitable for continuous operation.

It is not suitable for use in rooms where there is a potential risk of explosions.

It is not suitable for use in aggressive atmospheres.

The unit should be installed if possible in a covered room. If it is installed outdoors a roof is to be provided or the unit is to be covered.

Modifications to the lifting gear are only permitted with our express consent in writing.

Refer to the technical data and function description.

Safety instructions

Operation and servicing must be left strictly to: authorized, trained personnel.

- Only install the trolley on girders whose load capacity has been checked previously.
- Do not install the trolley on tapered girders.
- Stops on the ends of girders must not be moved or removed.
- Do not transport personnel or allow personnel to be located in the danger area.
- Do not allow the load to swing.
- Do not stand under a raised load.
- Never reach into moving parts.
- Defects are to be rectified immediately by trained personnel.
- Never leave the load off the ground without supervision.
- Loads may only be raised vertically. Do not raise loads at an angle.
- Do not use the trolley to pull items out of other items, release them or drag them sideways.
- The trolley may only be used to push or pull the load.
- Do not exceed the load capacity set out in the technical data.
- Check the raceway width and adjust the distance between the chassis flanges using the figures in the table.
- The hand chain is only designed for moving the load attached to the lifting gear and must not be used for any other purpose.
- Never slew the load off the ground without supervision.
- High strength parts such as the chain, hook and gear parts must not come into contact with free hydrogen, acids, alkalis, vapour or very aggressive cleaning products. They may become brittle and fracture.
- Conduct a risk analysis before use and verify EC conformity.
- Working temperature: -10°C to +50°C.

The chassis chain (hand chain)

- is only designed for moving the trolley and must not be used for any other purposes.
- must not be used to attach a load.
- must not be drawn over sharp edges.
- must not be twisted.
- Before you use the trolley check that it is correctly mounted on the girder.
- Conduct a visual inspection of the rollers every day. Pay special attention to the lateral play between the raceway girder and the rollers.
- Check that the bolts are secure and that the traverse is secure.

Commissioning

Function description

The roller chassis may only be pulled on the load, the load hook or the load chain of the lifting gear.

The roller chassis is to be attached to a horizontal raceway girder.

The raceway girder must be flat and horizontal.

The chassis width may be adjusted by spacing to the relevant girder width.

The chassis is designed without a brake.

The attached load may be moved either by pushing or pulling the load (rolling chassis) or by pulling the hand chain (gear chassis).

The movement speed should be such that the load can be braked by the user at any time.

Assembly and installation of the trolley on the girder

The trolleys can be adjusted to various girder flange widths.

1. Establish the girder dimensions (M) (flange width).
2. Check conformity with the data sheet.

Dismantled the trolley

- Unscrew the load bolt (undo the split pin (6), lock nut (5) and load bolt (2)).
 - Set the track width. The distance between the rims (F) must be approx. 2 mm.
- larger on chassis weighing up to 2000 kg than the actual (measured) girder flange width.
- There are adjusting washers (3), (4) on the load bolt.
 - The spacing dimension (M) is achieved by pushing adjusting washers from outside to inside (M is increased) or from inside to outside (M is reduced).

Do not leave out any adjusting washers.

- Tighten the lock nut (5) and secure it with the split pin.

Installation on the girder

Adjust the side plates (1) of the chassis to width "M" with the load bolt (2), adjusting washers (3) and (4), spacer tube (7) and lock nut (5) and fit them. Tighten the lock nuts and push the unit on to the front of the girder flange. If this is not possible, the chassis can also be installed on to the raceway girder from underneath. The lock nut on the side without the drive unit must be removed for this purpose. Pull the chassis halves apart until the chassis can be pushed on to the girder flange from underneath. Then push the chassis together again to the correct track width, tighten the lock nut and secure it with the split pin.

The side plates should not be stressed by the lock nut but should still be able to move on the load bolt (2).

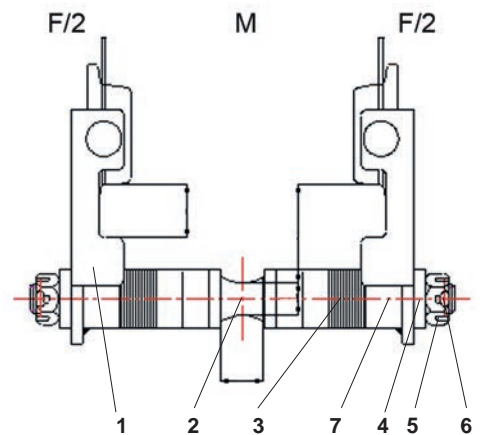

Commissioning

Ensure that the chains are correctly positioned; they must not be twisted and must hang freely.

Always refer to the operating manual of the lifting gear you are using.

The open meshing on the drive unit should be greased.

Function test:

Carefully move the chassis to the limit position and check the position of the limit stops.

Operation

Move the load by pulling the hand chain or by pushing the load.

Do not stand under a raised load.

Media / Recommended lubricants

Recommended lubricant for greasing points:

- Meshing, drive pinion

Multi-purpose grease DIN 51825 T1 K2K

After use the lubricant must be disposed of in compliance with the statutory regulations.

If the product is modified in any way, or if it is combined with a non-compatible product/component, CERTEX Group take no responsibility for the consequences in regard to the safety of the product.

Inspection and servicing instructions

Safety instructions

Remove all the strain from the girder trolley by suitable means before carrying out inspection and servicing work

Inspection intervals Conduct an expert inspection before commissioning	Servicing and inspection work
Daily	Visual inspection of rollers (for signs of cracks and deformation) Visual inspection of the chain Function of the unit Adjustment range, visual inspection of the track width lateral play
Quarterly	The rollers are fitted with ball bearings that are lubricated for life
Every six months	Check the condition of the hand chain (remove sharp edges as they constitute an injury risk) Check screw connections. Grease the meshing on the rollers and drive pinion.
Every year	Check that the model plate is completely legible. Have the annual test carried out by an expert

The service life of the unit is limited, worn parts must be replaced promptly by an expert.

Contact your dealer for spare parts in general.

Problem	Cause	Servicing and inspection work
The girder trolley can only be moved with difficulty.	No grease in the bearings and meshing.	Visual inspection of rollers (for signs of cracks or deformation)
	Dirt or other foreign bodies on load girder.	Visual inspection of the chain Function of the unit
	Girder deformed	Adjustment range, visual inspection of the track width lateral play

Instruction Grey Label

To change your new POWERTEX Trolley to Black Line:

If the product should be used in dark environments, add the grey label on the product's nameplate like this.

The data on the nameplate should ALWAYS be visible, and must NOT be covered.

Disposal:



After the trolleys have been taken out of use, the parts of the block and tackle are to be recycled or disposed of in compliance with the statutory regulations.

CERTEX Lifting KnowHow app

Download The Lifting KnowHow app'en from the App Store / Google play!

The App has the following features:

- Load charts for different types of lifting slings
- Protractor for measuring sling angles
- Instructions for safe use of a selection of lifting gear
- Built-in gps function that finds the Lifting Solutions Group office closest to your position.
- And a lot more.

The Lifting KnowHow is a unique knowledge transfer programme.



CertMax+

The CertMax+ system is a unique leading edge certification management system which is ideal for managing a single asset or large equipment portfolio across multiple sites. Designed by the Lifting Solutions Group, to deliver optimum asset integrity, quality assurance and traceability, the system also improves safety and risk management levels.



User Manuals

You can always find the valid and updated User Manuals on the web. The manual is updated continuously and valid only in the latest version.

NB! The English version is the Original instruction.

The manual is available as a download under the following link:
www.powertex-products.com/manuals



SVERO AB
Momarken 19
9556 50 Jönköping Sweden

POWERTEX



The Lifting KnowHow



www.powertex-products.com