

GB Instruction for use
LV Lietošanas pamācība

POWERTEX



Aluminum Lever Hoist PALH-S1

User Manual



POWERTEX Lever Hoist PALH-S1 0,25 – 3 ton

Instruction for use (GB) (Original instructions)

Read through these user instructions before using the lever hoist. Improper operation may lead to hazardous situations.

General safety provisions

- Only to be used by trained operator.
- Do not use in explosive or corrosive environment.
- Temperature range: -10°C up to +50°C.
- Check the function of the lever hoist before use. See “Daily checks” on page 4.
- Do not exceed the maximum load.
- Full function of the brake system can only be secured at a minimum load of 30 kg for capacities (WLL) up to 1 ton, and for capacities (WLL) above 1 ton, the minimum load to be greater than 3% of the rated capacity (WLL).
- Handle the lever hoist with care. Do not throw the hoist about or let it fall to the ground.
- Do not use the lever hoist for welding work where it is exposed to welding spatter or current.
- The lever hoist block must not be used for lifting persons.

0,25 - 1,5 t

3,0 t

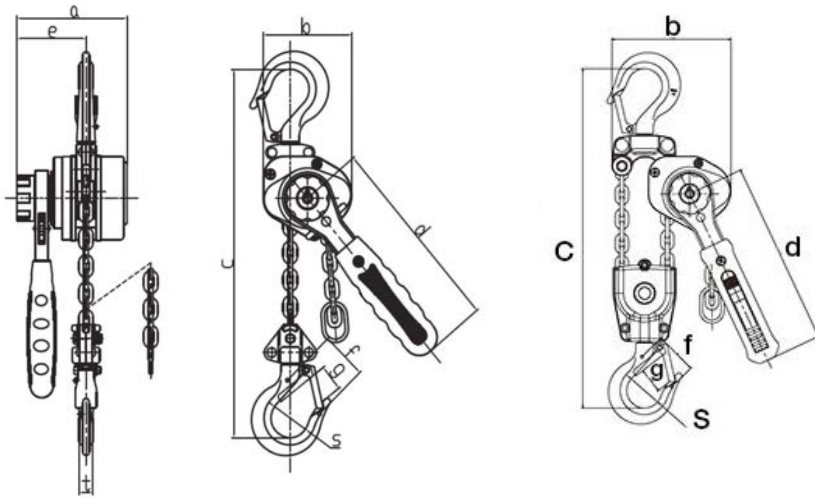

Data

Art No	Model	WLL ton	Hand force max. (N)	Load chain (mm)	Number of falls	Weight* (kg)	Weight** (kg)
16.20PALHS10025030	PALH-S1/250KG	0,25	290	3 x 9	1	1,45	1,95
16.20PALHS10050030	PALH-S1/500KG	0,5	270	4 x 12	1	2,50	3,30
16.20PALHS10075030	PALH-S1/750KG	0,75	330	5 x 15	1	3,40	4,30
16.20PALHS10150030	PALH-S1/1500KG	1,5	420	7,1 x 20,1	1	6,27	8,20
16.20PALHS10300030	PALH-S1/3000KG	3,0	430	7,1 x 20,1	2	9,11	12,4

Last 3 digits indicate the lifting height. For example 030 = 3,0 m
 *Weight for hoist with 1,5 m lift. **Weight for hoist with 3,0 m lift.

Dimensions

WLL ton	a (mm)	b (mm)	c (mm)	d (mm)	e (mm)	f (mm)	g (mm)	s (mm)	t (mm)
0,25	87	68	200	145	55,5	35,5	21	32	11
0,5	100,5	81	250	160	62,5	42	24,5	34,5	12
0,75	105	92	260	180	64	42	28,5	35,5	14
1,5	122	109	330	220	68,5	52	35	42,5	21,5
3,0	122	160	432	220	68,5	61,9	43	50	24,5

Safety factor: 4:1.
 Static test coefficient: WLL x 1,5.
 Generally according to EN 13157.

Function

Pulling through the unloaded chain

Make sure the chain is unloaded and set the selector to neutral position (N). Pull the chain through by hand to the desired position.



Warning! If the selector is in position UP or DOWN when the chain is pulled, the lever may rotate like a propeller, which could be dangerous.



Warning! If the lever hoist is used on a load which is too light, the brake function will not engage. The load must be at least 3% of maximum load. For example a minimum load of 30 kg is necessary to engage the brake on a 1 tonne hoist. For lightloads choose a smaller lever hoist.

If it proves impossible to pull the chain through despite the selector being in neutral, it may be necessary to release the brake first, by turning the brake wheel anti-clockwise. If this does not help, set the selector to position DOWN, load the chain slightly and jerk the lever in clockwise direction. Then try again without load but with the selector in neutral.

Suspension of lever hoist

Make sure the hoist is suspended from an eye, shackle or similar with sufficient bearing capacity. With the chain tightened, both hooks must be in line (Fig. 3a).



NB! Neither hoist, hooks nor chain may be subjected to bending stresses (Figs. 3b and c and Fig. 4).

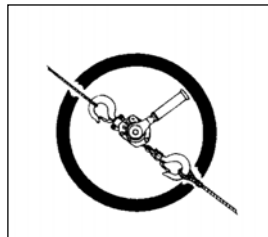

Fig 3 a

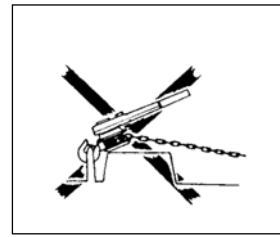

Fig 3 b

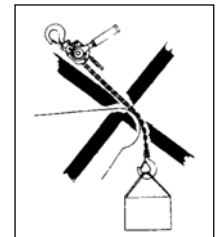

Fig 3 c

Attachment of loads

Check the equipment well before use. Improper attachment of loads can be highly dangerous (see Figs. 4 a–e).



Only use straps and slings of sufficient load capacity. Make sure the load is not anchored to the floor/ground or is otherwise fixed before making the lift.

Lifting/pulling

With the selector in position UP, operate the lever to tighten the chain. Check for safety before lifting the load to the desired position. If the load is too light to be lifted, hold onto the brake wheel so you hear the snapping sound. You will then be able to lift the load with just one hand. If the lever is released while lifting, the load will be held in its current position by the reaction brake. The lever hoist can also be used for pulling and fixing loads.



Fig 4 a

The sling is applying load to the hook tip!

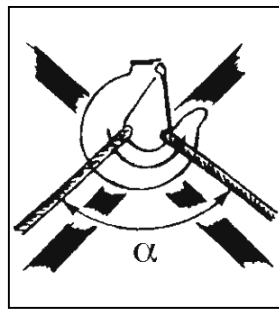

Fig 4 b

Excessive top angle on sling!
 α max. 60°

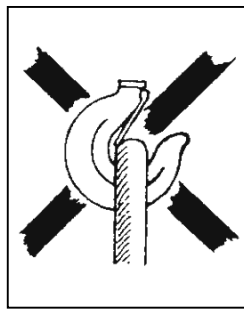

Fig 4 c

Hook latch obstructed!

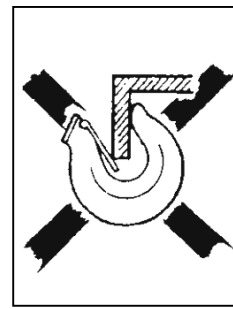

Fig 4 d

Hook tip subject to additional bending stress!

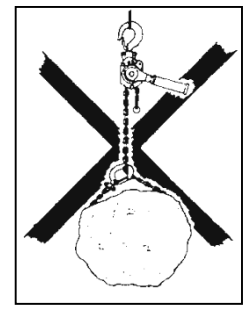

Fig 4 e

Load chain must not be used as a sling!

Further safety precautions

- Never lengthen the lifting lever with a pipe or similar. Use only hand power on the lever. If the load seems too heavy, use a bigger lever hoist or reduce the load.
- Make sure no-one stands beneath a hanging load.
- Do not raise or lower so far that the load hook or the stop eye hits the block housing.
- Do not set the selector to neutral under load.
- The block must not be subjected to dynamic stresses, for example where a load connected to the block is launched from a height.
- Do not leave a block with a suspended load unattended.

Lowering

With the selector in DOWN position, operate the lever to lower the load. Wait until the chain has been completely freed of load before moving the selector to Neutral (N) to rapidly pull out the chain. (See "Pulling through the unloaded chain").

Warning: Do not overload the brake by prolonged lowering. It may cause brake function to fail.

Multiple lifting

Multiple lifting presents special risks. This is when two or perhaps more hoists are used simultaneously for the same load. Danger to persons and material damage can arise due to dynamic stresses and uneven load distribution causing individual hoists to become overloaded. A competent person with experience in multiple lifting must therefore supervise this type of lifting tasks.

The total weight of the target object and its load distribution must be known or calculated. For a variety of reasons, the centre of gravity can be difficult to determine, and thus so will the distribution of the load each hoist must bear. In cases where heavy, bulky loads must be handled and it is not possible to estimate all factors correctly, the max working load limit (WLL) of each hoist must be reduced by at least 25%.

Daily checks

After every working day on which the lever hoist has been used, the following should be checked:

- Is the lever hoist deformed or otherwise damaged? Are any parts missing?
- Is any deformation or other damage visible on the suspension device (eye, shackle, bolt or similar)?
- Are the hooks intact or have any hooks opened? Are the hook latches correct and functional?
- The selector must work without problems.
- Wipe down the lever hoist and oil the chain as required.
- The chain must be undamaged, i.e. no signs of wear and no deformed or otherwise damaged links.
- The chain must not be kinked or twisted.
- The chain stop must free of deformation or other damage.
- The brake function must be intact.

In the event of faults or failures, the hoist must be repaired and carefully checked by a specialist before reuse.

Continuous maintenance - lubrication

Oil the hook latches and bearings. Grease the pawl and ratchet and also the gear. Lubrication must be sparingly and carefully applied so no grease gets on the brake disk. Oil the chain for longer life.

Periodic checks

Periodic checks are normally carried out yearly to detect and remedy any faults. If required (e.g. high frequency of use), more frequent checks may be carried out. See "Checklist for periodic checks". Measure hooks and chain to detect any changes in shape.

Hook checks (see fig 6 and Table 2)

Opening dimension E on the hooks is important. A hook with too large a maximum dimension has been exposed to overloading or overheating. It therefore does not have the necessary load capacity. The hooks may also have been exposed to long-term wear (dimension K).

Hooks must be discarded and replaced if:

- the maximum E value is exceeded (according to Table 2)
- the minimum K value falls short (according to Table 2)
- the hook is cracked, deformed or otherwise damaged.

Defective hooks must be replaced before using the lever hoist again!

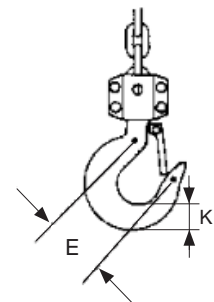

Fig. 6 Load hook

Table 2 Hook dimensions

Max. load ton	0,25	0,5	0,75	1,5	3,0
Model	PALH-S1	PALH-S1	PALH-S1	PALH-S1	PALH-S1
Dimension E nominal mm	35,47	41,70	41,56	52,08	62,0
Dimension E max. mm	38,29	44,84	44,69	55,73	66,5
Dimension K nominal mm	12,9	15,6	20,0	26,5	31,2
Dimension K min mm	11,6	14,0	18,0	23,8	28,0

Check measurement of chain (See Fig. 7 and table 3)

Inspect the chain over its whole length to detect any deformed or otherwise damaged links. Make a check measurement of suspect links. Measure the worn areas. Also, every 300 mm (normally), take check measurements of the internal length of 5 links (pitch dimension 5xP according to Table 3).

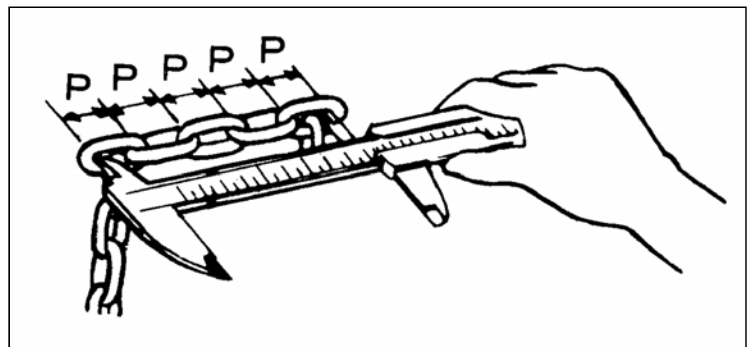

Fig 7 Checking chain dimensions

Table 3 Chain dimensions

Max. load ton	0,25	0,5	0,75	1,5	3,0
Model	PALH-S1	PALH-S1	PALH-S1	PALH-S1	PALH-S1
Link diameter nominal mm	3,0	4,0	5,0	7,1	7,1
Link diameter min. mm	2,7	3,6	4,5	6,4	6,4
Pitch dimension (5xP) nominal mm	45,0	60,0	85,0	100,5	100,5
Pitch dimension (5xP) max. mm	46,3	61,8	87,5	103,5	103,5

The chain must be discarded and replaced if:

- cracks are detected on any link
- any link is deformed or otherwise damaged
- The minimum value of any link's diameter falls short
- the maximum value of the pitch dimension is exceeded at any point
- the chain is damaged by overheating or has been affected by weld splatter

Chains must **not** be repaired – they must be replaced by a new original chain. If it is desired to lengthen the chain, it must be replaced by a new and longer chain.

Replacement of the chain shall be performed professionally by an authorized repairer and the chain must meet the requirements stated in the standard EN 818-7, Grade T from the following manufacturers: Chaineries Limousines, Pewag, Kito Chain, Retezarna or Rud.

Repairs

The lever hoist must not be modified. Repairs must be carried out by specialists. Damaged parts must only be replaced with original Powertex spare parts. Order them through your dealer.

Checklist for periodic checks (normally yearly – more frequently if necessary)

Daily	Yearly	Inspection items	Inspection method	Note
Labels				
X	X	Rating plate	Visual	If the plate is hard to read - replace it
Function				
X	X	Raising and lowering function	Test without load	A low snapping noise should be audible
-	X	Raising and lowering function	Test with 125% of rated load over a distance of min. 300 mm.	The lever runs easily. Load chain sprocket and chain work well together Brake works. The chain does not twist or tangle Hand pulling on the lever feels even
X	X	Selector	Operation	Easy to reset
X	X	Pulling through	Operation	Function
Hooks				
X	-	Hook opening	Visual	Looks normal
-	X		Measurement	See Fig. 6 and Table 2
X	X	Deformation	Visual	No visible deformation
X	X	Hook bearing	Visual	No abnormal play
X	-	Wear, cracks, deformation and corrosion	Visual	No visible damage
-	X		Measurement	See Fig. 6 and Table 2
X	X	Hook latches	Visual	Works, spring undamaged
Chain				
X	-	Pitch	Visual	Looks normal. Measure in case of doubt.
-	X		Measurement	See Fig. 7 and Table 3
X	-	Wear	Visual	Looks problem-free. Measure in case of doubt.
-	X		Measurement	See Fig. 7 and Table 3
X	X	Deformation	Visual	No deformation. Measure in case of doubt.
X	X	Cracks etc.	Visual	No cracks
X	X	Rust	Visual	No rust
Housing				
X	X	Housing	Visual	No deformation and no rust
-	X	Operating lever	Visual	No deformation
-	X	Load chain sprocket	Visual after dismantling	No serious wear or cracks. No fractures or deformation
-	X	Bearings	Visual, testing	No damage, smooth running
-	X	Gears	Visual after dismantling	No serious wear or fractures
X	X	Chain stop	Visual	Must be free of deformation
Screws				
X	X	Screws, nuts, rivets, cotters etc.	Visual	Must not be missing. Tighten loose items. Replace as necessary
Brake				
-	X	Brake disk	Visual	Replace if worn
-	X	Brake screw	Visual	No serious wear
-	X	Pawl and ratchet	Visual	Replace worn parts. Carefully lubricate with grease.

POWERTEX vinča ar sviru PALH-S1 0,25 – 3 tonnas Lietošanas pamācība (LV)

Pirms vinčas ar sviru izmantošanas izlasiet šo lietošanas pamācību. Nepareiza lietošana var būt bīstama!

Vispārēji drošības noteikumi

- Drīkst izmantot tikai apmācīta persona.
- Nelietojiet sprādzienbīstamā vai korozīvā vidē.
- Temperatūras diapazons -10°C un +50°C.
- Pirms vinčas lietošanas pārliecinieties, ka tā darbojas. Skatiet punktu „Ikdienas pārbaudes” 8. lappusē.
- Nepārsniedziet maksimāli pieļaujamo noslodzi.
- Bremžu sistēma pilnībā darbojas pie minimālās slodzes 30 kg, ja ražotāja noteiktā robežslodze ir līdz 1 tonnai, savukārt, ja robežslodze ir virs 1 tonnas, minimālajai slodzei jābūt lielākai nekā 3% no noteiktās ražotāja noteiktās robežslodzes.
- Rīkojieties ar vinču uzmanīgi. Nemētājiet vinču un neļaujiet tai nokrist zemē.
- Neizmantojiet vinču metināšanas darbos, kur tā var tikt pakļauta dzirksteļu vai strāvas iedarbībai.
- Vinču ar sviru nedrīkst izmantot cilvēku pacelšanai.

0,25 - 1,5 t

3,0 t

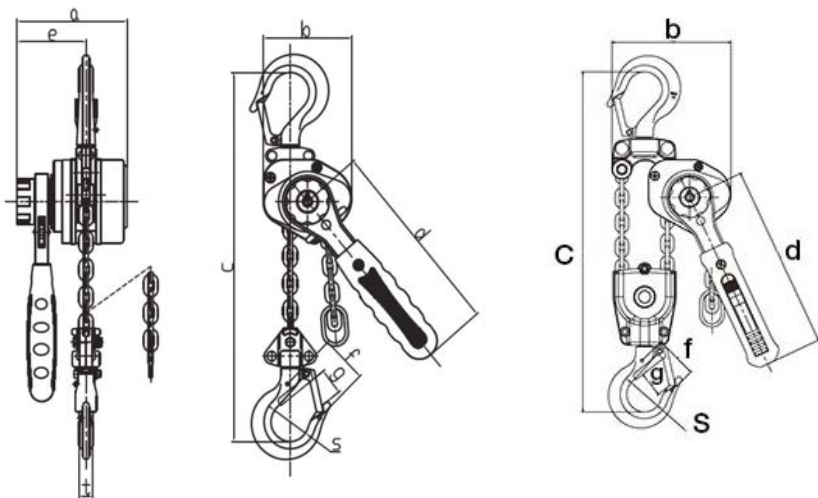

Tehniskie parametri

Artikula Nr.	Modelis	Celtspēja (WLL) Maks. pielietojamais roku spēks		Celšanas ķēde	Ķēdes kritumu skaits	Svars* (kg)	Svars** (kg)
		tonnās	(kg)				
16.20PALHS10025030	PALH-S1/250KG	0,25	290	3 x 9	1	1,45	1,95
16.20PALHS10050030	PALH-S1/500KG	0,5	270	4 x 12	1	2,50	3,30
16.20PALHS10075030	PALH-S1/750KG	0,75	330	5 x 15	1	3,40	4,30
16.20PALHS10150030	PALH-S1/1500KG	1,5	420	7,1 x 20,1	1	6,27	8,20
16.20PALHS10300030	PALH-S1/3000KG	3,0	430	7,1 x 20,1	2	9,11	12,4

Pēdējie trīs cipari norāda celšanas augstumu, piemēram 030 = 3,0 m

*Vinčas svars ar celšanas augstumu 1,5 m. **Vinčas svars ar celšanas augstumu 3,0 m.

Izmēri

Celtspēja (WLL) tonnās	a (mm)	b (mm)	c (mm)	d (mm)	e (mm)	f (mm)	g (mm)	s (mm)	t (mm)
0,25	87	68	200	145	55,5	35,5	21	32	11
0,5	100,5	81	250	160	62,5	42	24,5	34,5	12
0,75	105	92	260	180	64	42	28,5	35,5	14
1,5	122	109	330	220	68,5	52	35	42,5	21,5
3,0	122	160	432	220	68,5	61,9	43	50	24,5

Drošības koeficients: 4:1.

Statiskās pārbaudes koeficients: WLL x 1,5.

Vispārīgi atbilstoši EN 13157.

Darbība

Ķēdes bez kravas izvilšana

Ķēdei ir jābūt bez kravas, un selektoram jāatrodas brīvgaitas stāvoklī (N). Ar roku izvelciet ķēdi cauri blokam līdz vēlamajam stāvoklim.



Uzmanību! Ja ķēde tiek vilkta, kad selektors atrodas stāvoklī UZ AUGŠU vai UZ LEJU, svira var sākt rotēt kā propelleris, kas var būt bīstami.



Uzmanību! Ja vinču izmanto ļoti vieglu kravu celšanai, bremzes neiedarbosies. Kravas masai ir jābūt vismaz 3% no maksimālās noslodzes. Piemēram, lai iedarbinātu 1 tonnas vinčas bremzes, kravas smagumam ir jābūt vismaz 30 kg. Vieglu kravu celšanai izvēlieties mazāk jaudīgas vinčas.

Ja tad, kad selektors ir ieslēgts brīvgaitas pozīcijā, ķēdi nav iespējams pavilkt, iespējams, vispirms ir jāatlaiz bremzes, pagriežot bremžu ripu pretēji pulksteņrādītāja virzienam. Ja tas nedarbojas, iestatiet selektoru stāvoklī UZ LEJU, piestipriniet ķēdei nelielu kravu un paraujiet sviru pulksteniski. Pēc tam atkārtojiet to, bet šoreiz, iestatot selektoru brīvgaitas stāvoklī.

Vinčas ar sviru piekāršana

Vinča ir jāpiekarina pie pietiekami izturīgas cilpas, skavas utt. Kad ķēde ir nostiepta, abiem āķiem ir jāatrodas vienā līnijā (3.a attēls)



Uzmanību! Vinču, āķus un ķēdi nedrīkst pakļaut lieces spēka iedarbībai (3.b, 3.c un 4. attēls).

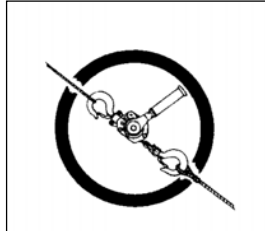

3. a attēls



3.b attēls

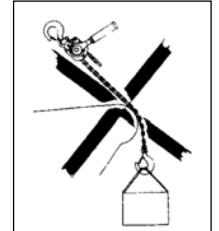

3.c attēls

Kravu stiprināšana

Pirms lietošanas kārtīgi pārbaudiet aprīkojumu. Nepareizi piestiprinātas kravas var būt ļoti bīstamas (skatiet 4.a–4.e attēlu).

Lietojiet tikai pietiekami izturīgas siksnas un cilpas. Pirms pacelšanas pārliecinieties, ka krava nav piestiprināta pie grīdas un ir kustināma.

Pacelšana/vilkšana

Ieslēdziet selektoru stāvoklī UZ AUGŠU un nostiepiet ķēdi ar sviru. Pirms kravas pārvietošanas uz vēlamo vietu pārliecinieties par drošību. Ja krava ir pārāk viegla pacelšanai, pieturiet bremžu ripu, lai būtu dzirdama klikšķoša skaņa. Tad kravu var pacelt ar vienu roku. Ja kravas pacelšanas laikā svira tiek atlaista, bremzes noturēs kravu nekustīgā stāvoklī. Vinču ar sviru var izmantot arī kravu vilkšanai un remontam.



4. a attēls.

Cilpa rada pārlieku lielu slodzi uz āķa galu!

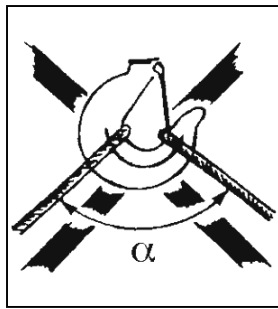

4.b attēls.

Pārlieku liels cilpas augšējais leņķis!
α maks. 60°

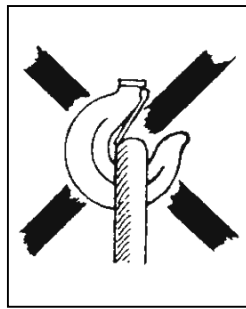

4.c attēls.

Bloķēts āķa aizturis!

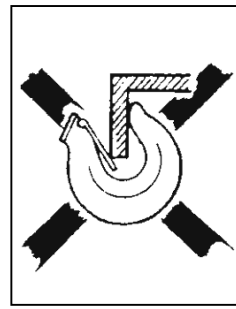

4.d attēls.

Āķa gals tiek liekts!

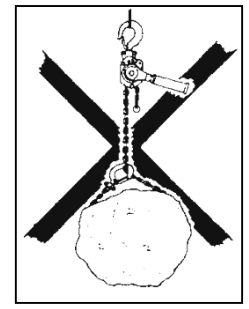

4.e attēls.

Kravas ķēdi nedrīkst izmantot cilpas vietā!

Citi drošības noteikumi

- Nekādā gadījumā neizmantojiet sviras pagarināšanai cauruli vai tamlīdzīgus priekšmetus. Sviru drīkst darbināt tikai ar rokām. Ja krava šķiet pārāk smaga, izmantojiet lielāku vinču vai samaziniet kravas masu.
- Zem paceltas kravas nedrīkst atrasties cilvēki.
- Neļaujiet kravas āķim vai aiztura cilpai pacelšanas vai nolaišanas laikā saskarties ar bloka korpusu.
- Neiestatiet selektoru brīvgaitas stāvoklī, kad ir pacelta krava.
- Bloku nedrīkst pakļaut dinamiskās slodzes iedarbībai, piemēram, metot zemē pie bloka piestiprinātu kravu.
- Neatstājiet paceltu kravu bez uzraudzības.

Nolaišana

Ieslēdziet selektoru stāvoklī UZ LEJU un ar sviru nolaidiet kravu zemāk. Pagaidiet, kamēr ķēde tiek pilnīgi atslogota, iestatiet selektoru brīvgaitas (N) stāvoklī un strauji izvelciet ķēdi. (Skatiet punktu „Ķēdes bez kravas izvilšana”).

Brīdinājums: Nepārslogojiet bremzi nolaižot kravu pārlieku lēni. Tas var izraisīt bremžu darbības traucējumus.

Kombinētā pacelšana

Kombinētā pacelšana ir sevišķi bīstama. Kombinētā pacelšana ir kravas pacelšana ar divām vai vairākām vinčām vienlaikus. Dinamiskās slodzes un nevienmērīgs slodzes sadalījums var izraisīt atsevišķu vinču pārslodzi, kas savukārt rada apdraudējumu cilvēkiem un materiāla kaitējuma risku. Tāpēc kombinētā pacelšana jāuzrauga speciālistam ar pieredzi šāda veida pacelšanas darbos.

Jāuzzina vai jāapbrēķina kopējais mērķa objekta svars un slodzes sadalījums.

Dažādu iemelsu dēļ varētu būt grūti aprēķināt smaguma centru un tādējādi arī slodzi, kas jāiztur katrai vinčai. Ja jāpaceļ ļoti smagas beramkravas un nav iespējams pareizi novērtēt visus faktorus, katras vinčas maksimālā pieļaujamā slodze (MPS) jāsamazina vismaz par 25%.

Ikdienas pārbaudes

Katras darba dienas beigās pēc vinčas ar sviru izmantošanas ir jāpārbauda:

- Vai vinča nav deformēta vai citādi bojāta? Vai nav pazudušas kādas detaļas?
- Vai ir redzami kādi vizuāli piekares ierīces (cilpas, skavas, skrūves u.c.) bojājumi?
- Vai āķi ir veseli un neviens no tiem nav atvēries? Vai āķu aizturi ir atbilstoši un darbojas?
- Selektoram ir jādarbojas bez problēmām.
- Noslaukiet vinču un ieeļļojiet ķēdi pēc vajadzības.
- Ķēde nedrīkst būt bojāta, t.i., tajā nedrīkst būt nodilušu, deformētu vai citādi bojātu posmu.
- Ķēde nedrīkst būt savijusies vai samezglota.
- Ķēdes aizturis nedrīkst būt deformēts vai citādi bojāts.
- Bremzēm ir jābūt darba kārtībā.

Ja tiek atklātas kļūmes vai defekti, pirms darba turpināšanas pacelšanas ierīce ir jāsalabo un rūpīgi jāpārbauda speciālistam.

Regulāra apkope - eļļošana

Ieeļļojiet āķu aizturus un gultņus. Ieeļļojiet sprūdu un sprūdratu, kā arī zobratu. Eļļošana ir jāveic piesardzīgi un uzmanīgi, lai eļļa nenonāktu uz bremžu diska. Ieeļļojiet ķēdi, lai paildinātu tās kalpošanas laiku.

Periodiskās pārbaudes

Lai konstatētu un novērstu defektus, reizi gadā jāveic periodiskas apkopes. Ja nepieciešams (piemēram, ja ierīce tiek izmantota ļoti daudz), pārbaudes var veikt biežāk. Skatiet punktu „Periodisko pārbaudu kontrolsaraksts”. Veiciet āķu un ķēžu mērījumus, lai konstatētu to formas izmaiņas.

Āķu pārbaude (skatiet 6. attēlu un 2. tabulu.)

Ir svarīgs āķu atveres E platums. Ja šis izmērs āķiem ir pārāk liels, tie var tikt pārslogoti un pārkarst. Tāpēc tiem nav nepieciešamās kravnesitības. Āķu nodilums var rasties arī ilgstošā laikā (izmērs K).

Āķi ir jāmaina, ja:

- ir pārsniegts maksimāli pieļaujamais E izmērs (saskaņā ar 2. tabulu),
- izmērs K ir mazāks nekā minimāli pieļaujamais (saskaņā ar 2. tabulu),
- āķis ir ieplaisājis, deformēts vai citādi bojāts.

Pirms atsākt lietot ķēdes bloku, bojātie āķi ir jāmaina.

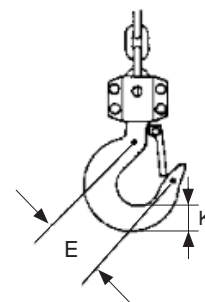

6. attēls

2. tabula. Āķu izmēri

Maksimālā slodze, tonnās	0,25	0,5	0,75	1,5	3,0
Modelis	PALH-S1	PALH-S1	PALH-S1	PALH-S1	PALH-S1
Izmērs E nominālais mm	35,47	41,70	41,56	52,08	62,0
Izmērs E maksimālais mm	38,29	44,84	44,69	55,73	66,5
Izmērs K nominālais mm	12,9	15,6	20,0	26,5	31,2
Izmērs K minimālais mm	11,6	14,0	18,0	23,8	28,0

Ķēdes mērīšana (skatiet 7. attēlu)

Pārbaudiet ķēdi visā tās garumā, lai pārliecinātos, ka tajā nav deformētu vai citādi bojātu posmu. Izmēriet posmus, kuri liekas šaubīgi. Izmēriet nodilušās vietas. Ik pēc 300 mm (apmēram) izmēriet arī 5 posmu kopējo garumu (soļa garums 5xP – saskaņā ar 3. tabulu).

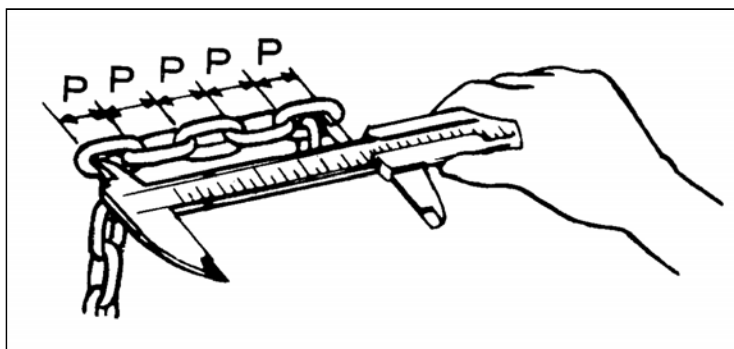

7. attēls. Ķēdes mērīšana

3. tabula. Ķēdes izmēri

Maksimālā slodze, tonnās	0,25	0,5	0,75	1,5	3,0
Modelis	PALH-S1	PALH-S1	PALH-S1	PALH-S1	PALH-S1
Posma diametrs, nominālais mm	3,0	4,0	5,0	7,1	7,1
Posma diametrs, minimālais mm	2,7	3,6	4,5	6,4	6,4
Soļa garums (5xP) nominālais mm	45,0	60,0	85,0	100,5	100,5
Soļa garums (5xP) maksimālais mm	46,3	61,8	87,5	103,5	103,5

Ķēde ir jāmaina, ja:

- kāds no posmiem ir ieplaisājis,
- kāds no posmiem ir deformēts vai citādi bojāts,
- kāda posma diametrs ir mazāks par minimāli pieļaujamo,
- kādā vietā tiek pārsniegts maksimāli pieļaujama soļa garums,
- ķēde ir tikusi sabojāta karstuma vai metināšanas dzirksteļu ietekmē

Ķēdes **nedrīkst** remontēt – tās ir jāmaina pret jaunām, oriģinālām ķēdēm. Ja vēlaties ķēdi pagarināt, ir jāiegādājas jauna, garāka ķēde.

Aizstāšana ķēdes veic profesionāli pilnvarotā remontētāja un ķēde ir jāatbilst noteiktajām prasībām standartā EN 818-7, klase T no šādiem ražotājiem: Chaineries Limousines, Pewag, Kito Chain, Retezarna vai Rud.

Remontdarbi

Vinču ar sviru nedrīkst modificēt. Remontdarbus drīkst veikt tikai speciālisti. Bojātās detaļas ir jāmaina ar oriģinālām Powertex detaļām. Pasūtiet tās pie sava piegādātāja.

Periodisko pārbaūžu kontrolsaraksts (parasti – reizi gadā, ja nepieciešams – biežāk)

Ikdienas	Reizi gadā	Pārbaudes objekts	Pārbaudes metode	Piezīmes
Marķējums				
X	X	Tehniskā plāksnīte	Vizuāli	Ja uzraksti uz tehniskās plāksnītes ir grūti salasāmi, tā ir jāmaina.
Darbība				
X	X	Pacelšana un nolaišana	Pārbaude bez kravas	Ir jābūt dzirdamai klusai, klikšķošai skaņai.
-	X	Pacelšana un nolaišana	Pārbaudiet ar 125% no maksimālās noslodzes vismaz 300 mm augstumā.	Svira kustas viegli. Kravas ķēdes rats un ķēde darbojas labi. Bremzes darbojas. Ķēde nesagriežas un nesapinas. Sviru var vienmērīgi pavilkt ar roku.
X	X	Selektors	Lietošana	Viegli atiestatīt
X	X	Vilkšana cauri	Darbība	Darbojas
Āķi				
X	-	Āķa atveres platums	Vizuāli	Izskatās normāli
-	X		Mērīšana	Skatiet 6. attēlu un 2. tabulu.
X	X	Deformācija	Vizuāli	Deformācija nav saskatāma
X	X	Āķa gultnis	Vizuāli	Normāls brīvgājiens
X	-	Nodilums, plaisas, deformācija un korozija	Vizuāli	Nav redzamu defektu
-	X		Mērīšana	Skatiet 6. attēlu un 2. tabulu.
X	X	Āķa aizslēgs.	Vizuāli	Darbojas, atspere nav bojāta.
Ķēde				
X	-	Solis	Vizuāli	Izskatās normāli Izmēriet, ja šaubāties
-	X		Mērīšana	Skatiet 7. attēlu un 3. tabulu.
X	-	Nodilums	Vizuāli	Izskatās kārtībā Izmēriet, ja šaubāties
-	X		Mērīšana	Skatiet 7. attēlu un 3. tabulu.
X	X	Deformācija	Vizuāli	Deformācijas nav. Izmēriet, ja šaubāties.
X	X	Plaisas u.tml.	Vizuāli	Plaisu nav
X	X	Rūsa	Vizuāli	Rūsas nav
Korpuss				
X	X	Korpuss	Vizuāli	Deformācijas un rūsas nav
-	X	Vadības svira	Vizuāli	Deformācijas nav
-	X	Kravas ķēdes rats	Vizuāli pēc demontāžas	Nav būtiska nodiluma vai plaisu Nav plīsumu un deformācijas
-	X	Gultņi	Vizuāli, pārbaude	Bez bojājumiem, vienmērīga darbība
-	X	Zobratī	Vizuāli pēc demontāžas	Nav būtiska nodiluma vai plaisu
X	X	Ķēdes aizturis	Vizuāli	Nedrīkst būt deformēts.
Skrūves				
X	X	Skrūves, uzgriežņi, kniedes, tapas utt.	Vizuāli	Nedrīkst būt nozaudētas. Pievelciet, ja vajīgi. Ja vajadzīgs, nomainiet.
Bremze				
-	X	Bremžu disks	Vizuāli	Nomainiet, ja nodilis
-	X	Bremžu skrūve	Vizuāli	Bez būtiska nodiluma
-	X	Sprūds un sprūdrats	Vizuāli	Nomainiet nodilušās detaļas. Uzmanīgi ieeļļojiet ar smērvielu.

POWERTEX Lever Hoist PALH-S1 – Spare parts

When ordering spare parts, specify model, WLL, part number and the quantity needed.
When ordering chain, also specify lifting height.

If the load chain has been damaged or worn out the load sheave probably has to be replaced.

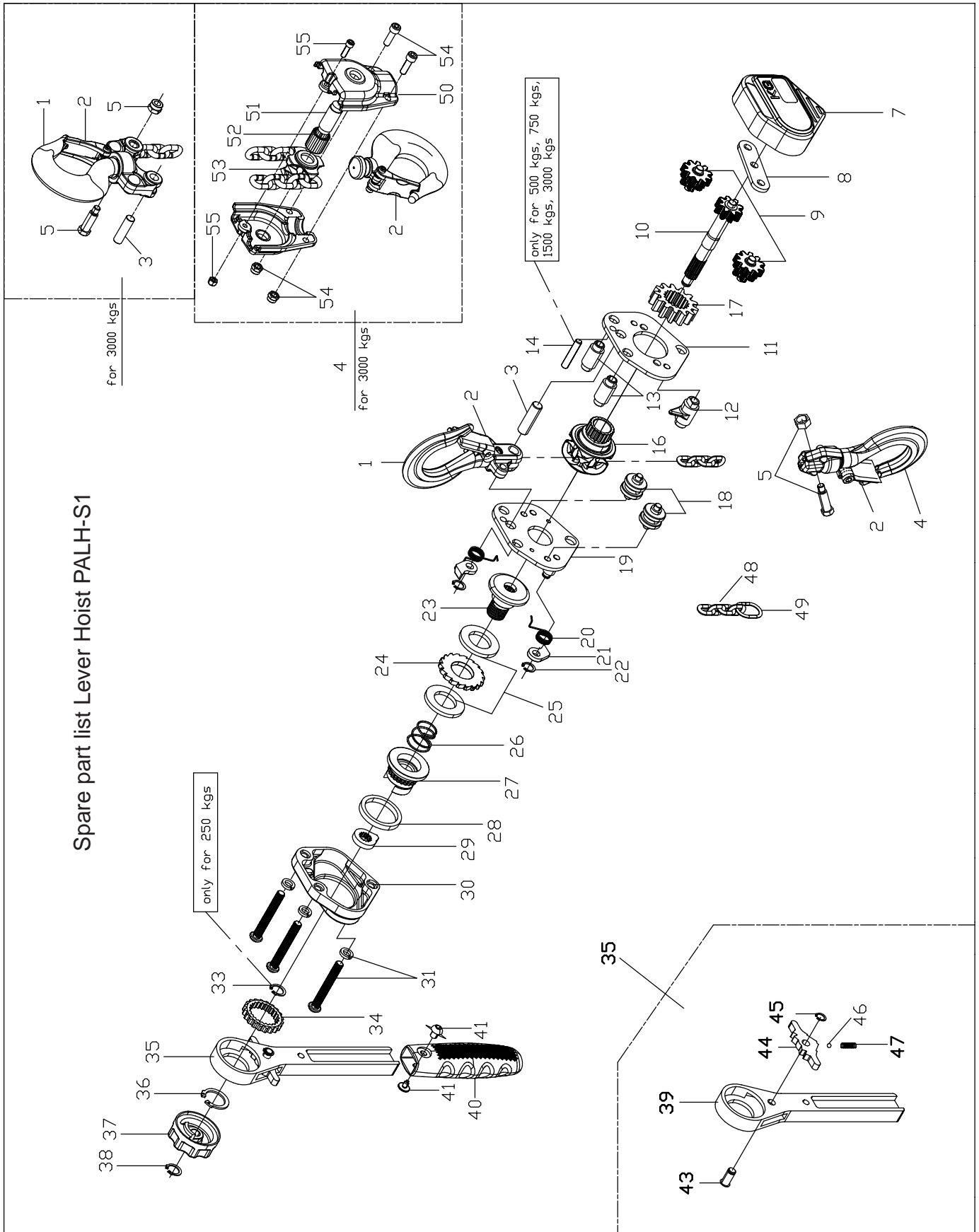

Pos	Description	Qty	250 kg	500 kg	750 kg	1500 kg	3000 kg
1	Top hook assembly (incl. #2)	1	16.20PALHS10250-1	16.20PALHS10500-1	16.20PALHS10750-1	16.20PALHS11500-1	
2	Safety latch kit	2	16.20PALHS10250-2	16.20PALHS10500-2	16.20PALHS10750-2	16.20PALHS11500-2	
3	Top hook shaft	2	16.20PALHS10250-3	16.20PALHS10500-3	16.20PALHS10750-3	16.20PALHS1150-3	~
4	Bottom hook assembly (incl. 2#)	1	16.20PALHS10250-4	16.20PALHS10500-4	16.20PALHS10750-4	16.20PALHS1150-4	~
5	Chain pin and locking nut	1	16.20PALHS10250-5	16.20PALHS10500-5	16.20PALHS10750-5	16.20PALHS1150-5	~
7	Gear case	1	16.20PALHS10250-7	16.20PALHS10500-7	16.20PALHS10750-7	16.20PALHS1150-7	~
8	Reinforced plate	1	16.20PALHS10250-8	16.20PALHS10500-8	16.20PALHS10750-8	16.20PALHS1150-8	~
9	Load gear	2	16.20PALHS10250-9	16.20PALHS10500-9	16.20PALHS10750-9	16.20PALHS1150-9	~
10	Driving pinion	1	16.20PALHS10250-10	16.20PALHS10500-10	16.20PALHS10750-10	16.20PALHS1150-10	~
11	Right side plate	1	16.20PALHS10250-11	16.20PALHS10500-11	16.20PALHS10750-11	16.20PALHS1150-11	~
12	Chain stripper	1	16.20PALHS10250-12	16.20PALHS10500-12	16.20PALHS10750-12	16.20PALHS1150-12	~
13	Stay bolt	2	16.20PALHS10250-13	16.20PALHS10500-13	16.20PALHS10750-13	16.20PALHS1150-13	~
14	Pin	1	-	16.20PALHS10500-14	16.20PALHS10750-14	16.20PALHS1150-14	~
16	Load gear	1	16.20PALHS10250-16	16.20PALHS10500-16	16.20PALHS10750-16	16.20PALHS1150-16	~
17	Load sheave	1	16.20PALHS10250-17	16.20PALHS10250-17	16.20PALHS10750-17	16.20PALHS1125-17	~
18	Chain guide	2	16.20PALHS10250-18	16.20PALHS10500-18	16.20PALHS10750-18	16.20PALHS1150-18	~
19	Left side plate assembly	1	16.20PALHS10250-19	16.20PALHS10500-19	16.20PALHS10750-19	16.20PALHS1150-19	~
20	Pawl spring	2	16.20PALHS10250-20	16.20PALHS10500-20	16.20PALHS10750-20	16.20PALHS1150-20	~
21	Pawl	2	16.20PALHS10250-21	16.20PALHS10500-21	16.20PALHS10750-21	16.20PALHS1150-21	~
22	Snap ring for pawl	2	16.20PALHS10250-22	16.20PALHS10500-22	16.20PALHS10750-22	16.20PALHS1150-22	~
23	Brake seat	1	16.20PALHS10250-23	16.20PALHS10500-23	16.20PALHS10750-23	16.20PALHS1150-23	~
24	Ratchet disc	1	16.20PALHS10250-24	16.20PALHS10500-24	16.20PALHS10750-24	16.20PALHS1150-24	~
25	Friction disc	2	16.20PALHS10250-25	16.20PALHS10500-25	16.20PALHS10750-25	16.20PALHS1150-25	~
26	Spring	1	16.20PALHS10250-26	16.20PALHS10500-26	16.20PALHS10750-26	16.20PALHS1150-26	~
27	Brake plate	1	16.20PALHS10250-27	16.20PALHS10500-27	16.20PALHS10750-27	16.20PALHS1150-27	~
28	Bushing	1	16.20PALHS10250-28	16.20PALHS10500-28	16.20PALHS10750-28	16.20PALHS1150-28	~
29	Stop knob	1	16.20PALHS10250-29	16.20PALHS10500-29	16.20PALHS10750-29	16.20PALHS1150-29	~
30	Brake cover	1	16.20PALHS10250-30	16.20PALHS10500-30	16.20PALHS10750-30	16.20PALHS1150-30	~
31	Socket head screw and spring washer	3	16.20PALHS10250-31	16.20PALHS10500-31	16.20PALHS10750-31	16.20PALHS1150-31	~
33	Snap ring for brake seat	1	16.20PALHS10250-33	-	-	-	~
34	Change over gear	1	16.20PALHS10250-34	16.20PALHS10500-34	16.20PALHS10750-34	16.20PALHS1150-34	~
35	Lever handle assembly	1	16.20PALHS10250-35	16.20PALHS10500-35	16.20PALHS10750-35	16.20PALHS1150-35	~
	Lever handle	1	16.20PALHS10250-39	16.20PALHS10500-39	16.20PALHS10750-39	16.20PALHS1150-39	~
	Selector lever	1	16.20PALHS10250-43	~	~	16.20PALHS1150-43	~
	Change over pawl	1	16.20PALHS10250-44	16.20PALHS10500-44	~	16.20PALHS1150-44	~
	Snap ring for change over pawl	1	16.20PALHS10250-45	~	~	~	~
	Roller	1	16.20PALHS10250-46	~	~	~	~
	Change over spring	1	16.20PALHS10250-47	~	~	~	~
36	Snap ring	1	16.20PALHS10250-36	16.20PALHS10500-36	16.20PALHS10750-36	16.20PALHS1150-36	~
37	Hand wheel	1	16.20PALHS10250-37	16.20PALHS10500-37	16.20PALHS10750-37	16.20PALHS1150-37	~
38	Snap ring for hand wheel	1	16.20PALHS10250-38	~	~	~	~
40	Handle sleeve	1	16.20PALHS10250-40	16.20PALHS10500-40	16.20PALHS10750-40	16.20PALHS1150-40	~
41	Bolt and nut	1	16.20PALHS10250-41	~	~	~	~
48	Load chain	1	16.908187030E	16.908187040E	16.908187050E	16.908187071E	16.908187071E
49	End ring	1	16.20PALHS10250-49	16.20PALHS10500-49	16.20PALHS10750-49	16.20PALHS1150-49	~
50	Bottom hook holder	2	-	-	-	-	16.20PALHS1300-50
51	Idle shaft	1	-	-	-	-	16.20PALHS1300-51
52	Quill roller	22	-	-	-	-	16.20PALHS1300-52
53	Idle sheave	1	-	-	-	-	16.20PALHS1300-53
54	Screw and nut	2	-	-	-	-	16.20PALHS1300-54
55	Screw and nut	1	-	-	-	-	16.20PALHS1300-55

CertMax+

The CertMax+ system is a unique leading edge certification management system which is ideal for managing a single asset or large equipment portfolio across multiple sites. Designed by the Lifting Solutions Group, to deliver optimum asset integrity, quality assurance and traceability, the system also improves safety and risk management levels.



Marking

The POWERTEX Lever Hoist is equipped with a RFID (Radio-Frequency Identification) tag, which is a small electronic device, that consist of a small chip and an antenna. It provides a unique identifier for the block.



The POWERTEX Lever Hoist is **CE** marked

Standard: EN 13157



Warning tag

The warning tag shows some specific and important situations, in which you must pay special attention, when using POWERTEX Chain Blocks and Lever Hoists.



User Manuals

You can always find the valid and updated User Manuals on the web. The manual is updated continuously and valid only in the latest version.

NB! The English version is the Original instruction.

The manual is available as a download under the following link:
www.powertex-products.com/manuals



Product compliance and conformity

SCM Citra OY
 Juvan Teollisuuskatui 25 C
 02920 Espoo
 Finland
www.powertex-products.com



POWERTEX

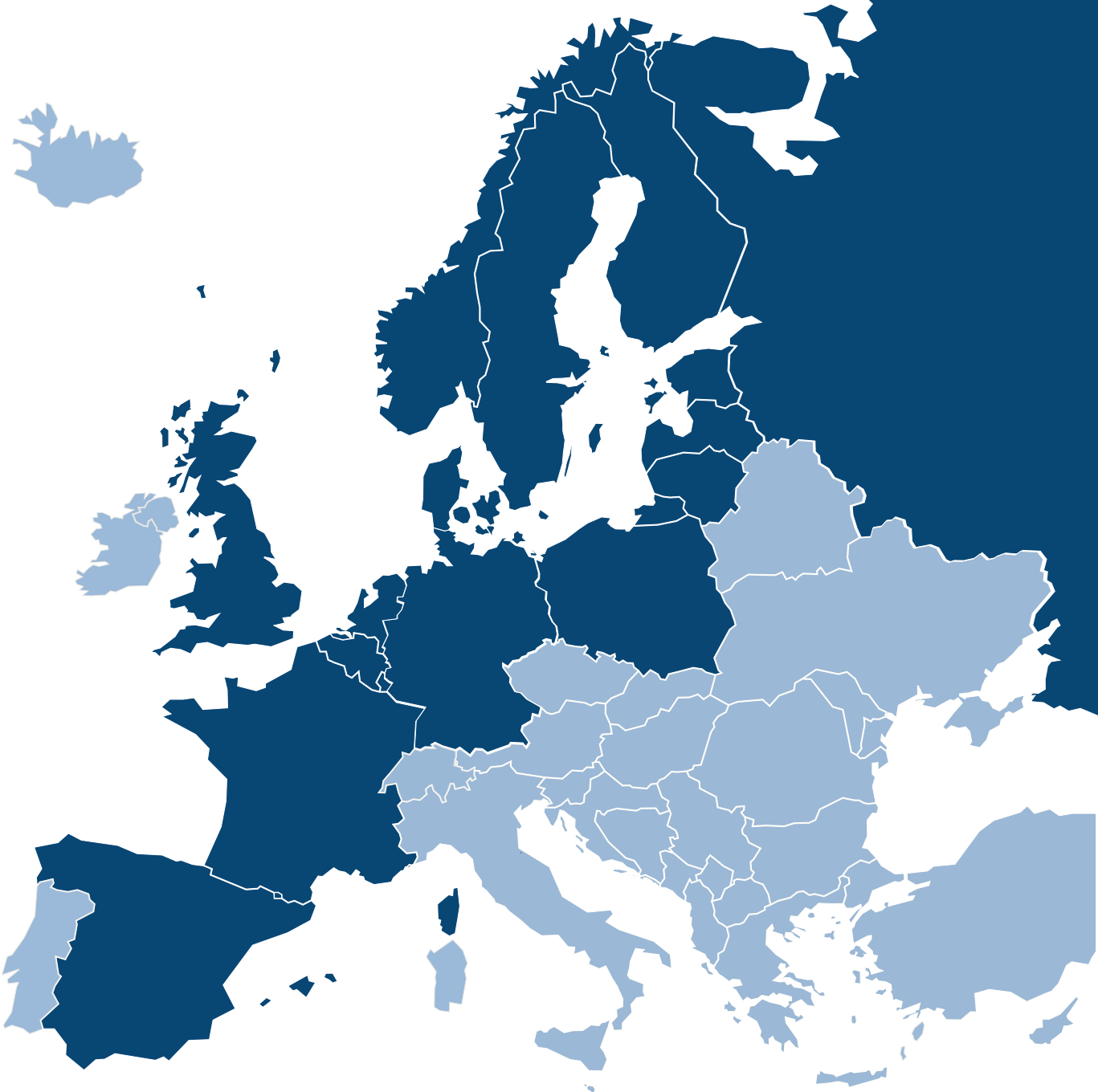

www.powertex-products.com